



राष्ट्रीय उन्नत विनिर्माण प्रौद्योगिकी संस्थान  
(पूर्व नेशनल इंस्टीट्यूट ऑफ फाउंड्री एंड फोर्ज टेक्नोलॉजी)  
हटिया, राँची - 834 003 (झारखण्ड)

**National Institute of Advanced Manufacturing Technology**  
(Formerly National Institute of Foundry and Forge Technology)  
Hatia, Ranchi – 834 003 (Jharkhand)

Ref. No.: NIAMT/S&P/164/2022-23

Dated: 05.04.2023

**NOTICE INVITING TENDER**

NIAMT invites tender from the reputed manufacturers or their authorized dealers so as to reach this office on or before scheduled date and time for the Equipments / Instruments, as per specifications given in the Annexure attached to the Tender form. All offers should be made in English and should be written in both figures and words. Tender forms can be downloaded from the website ([www.nifft.ac.in](http://www.nifft.ac.in)) of the Institute.

The bidders are requested to read the tender document carefully and ensure compliance with all specifications / instructions herein. Non-compliance with specifications / instructions in this document may disqualify the bidders from the tender exercise. The Director, NIAMT reserves the right to select the item (in single or multiple units) or to reject any quotation wholly or partly without assigning any reason. Incomplete tenders, amendments, and additions to tender after opening or late tenders are liable to be ignored and rejected.

**EQUIPMENT DETAILS**

Sl. No.	Ref. No.	Item Description	Qty	EMD	Performance Security
1	NIAMT/S&P/164/2022-23	Name of Equipment: - Fabricated Powder Extruder <b>Annexure-7</b>	01 Nos	Rs. 75,000.00	10% of P.O Value

**IMPORTANT NOTE, DATES & TIME**

Date and Time of Pre-bid Meeting	:	<b>17/04/2023 at 11:30 A.M.</b>
Last Date & Time for Submission	:	<b>23/05/2023 at 03:00 P.M.</b>
Date / Time of Opening of Bids	:	<b>23/05/2023 at 03:30 P.M.</b>
Venue of tender submission and Bid Opening at NIAMT	:	National Institute of Advanced Manufacturing Technology, Hatia, Ranchi – 834003 (Jharkhand)

### **Pre-Bid Meeting (PBM)**

- The objective of PBM is to provide a platform for clarifying issues and clearing doubts, if any, about the specifications and other allied technical/commercial details of the bid document. Bidders are requested to submit their bids only after the PBM so as to take care of the changes made in the bidding document, if any.
- The prospective participants should inform their intention to participate and send written queries at the email: [purchase@niamt.ac.in](mailto:purchase@niamt.ac.in) positively up-to **14/04/2023** to enable us to keep the response ready. Queries after **14/04/2023** Up-to **04.00 P.M.** will not be entertained.
- Change in the Technical Specifications and Terms & Conditions if any, for the above item after pre-bid deliberations, will be uploaded on the NIAMT website & CPPP Website. All vendors are requested to quote accordingly.

### **IMPORTANT NOTE:**

- **PLEASE STRICTLY ADHERE TO THE DATES / TIMES MENTIONED IN TENDER DOCUMENT**
- The **bids** (Technical Bids) will be **opened** in the presence of representatives of tenderers, if any. **If any unscheduled holiday occurs on the date of submission/opening, then next working day shall be the prescribed date of submission/opening. Requests for postponement will not be entertained.** Fax / email bids may not be accepted. The institute shall not be responsible for any postal delay about non-receipt / non delivery of the bids or due to any reason. Late / Delayed tenders shall not be considered / entertained.

The Director, NIAMT reserves the right to accept/reject any offer in part or full without assigning any reason.

### **TERMS AND CONDITIONS**

Important Conditions of the tender to be abide by the tenderer:

1. **Due date:** The tender has to be submitted before the due date. The offers received after the due date and time will not be considered.
2. **Preparation Bids:** The offer/bid should be submitted in **Two Bid Systems (i.e.) Technical Bid and Financial Bid**. The technical bid should consist of (a). Technical details of equipment (b). Printed brochure (c). Compliance statement technical bids (Annexure-4A) (d). Compliance statement of technical specification (Annexure-4B) along with commercial terms and conditions. Financial bid should indicate item wise price for the items mentioned in the technical bid. The Technical bid and the financial bid should be put in separate covers and sealed. Both the sealed covers should be put into a bigger cover along with letter of EMD and to be sealed. The tender number and details should be superscripted on the left side of the outer cover. The Quotations should be valid for 180 days from the date of opening of tender. The Quotations duly sealed and super scribed on the envelope with the reference No. and due date, should be addressed to **"The Director, National Institute of Advance Manufacturing Technology, Hatia, Ranchi – 834 003 (Jharkhand)"** so as to reach on or before the due date.

3. **Delivery of the tender:** The tender shall be sent to the below mentioned addressee either by post or by courier so as to reach our office before the due date specified in our Schedule. The offer/bid can also be dropped in the tender box on or before the due date and time specified in the schedule. The tender box is kept in Foyer area of NIAMT.
4. **Opening of the tender:** The offer / bid will be opened by a committee duly constituted for this purpose. The technical bid will be opened first and it will be examined by a technical committee which will decide the suitability as per our specification and requirement. The financial offer / bid will be opened only for the offers / bids which technically meet all our requirements as per the specifications. The bidders if interested may participate on the tender opening Date and Time. The bidder should produce authorization letter from their company to participate in the tender opening. Only one representative will be allowed to participate in the tender opening from each bidder.
5. **Acceptance / Rejection of bids:** The Committee reserves the right to reject any or all offers without assigning any reason.
6. **Pre-qualification criteria:**
  - i. Bidders should be the manufacturer / authorized dealer. Letter of Authorization from original equipment manufacturer (OEM) on the same and specific to the tender should be enclosed.
  - ii. An undertaking from the OEM is required stating that they would facilitate the bidder on a regular basis with technology/product updates and extend support for the warranty as well.
  - iii. OEM should be internationally reputed Branded Company.
  - iv. Non-compliance of tender terms, non-submission of required documents, lack of clarity of the specifications, contradiction between bidder specification and supporting documents etc. may lead to rejection of the bid.
7. **Tender Fee/EMD:** Tender fee /EMD is to be obtained from the bidders except those who are registered with the Central Purchase Organization, National Small Industries Corporation (NSIC) or the concerned Ministry or Department. The tenderer should submit Tender Fee / EMD amount as per tender ref. no. through NEFT / RTGS in NIFFT Account. Account Details are as follows:
  - a. Name of Beneficiary: **National Institute of Advanced Manufacturing Technology (NIAMT)**
  - b. Account No.: **2730101006939**
  - c. Name of Bank: **Canara Bank, NIAMT CAMPUS Branch,**
  - d. Bank Address: **Hatia, Ranchi – 834 003 (Jharkhand)**
  - e. IFS Code: **CNRB0002730**
  - f. MICR Code: **834015008**
  - g. Swift Code: **CNRBINBBCFD**The details of transaction for Tender Fee/EMD viz. Name of bidder firm, Tender Description, Transaction ID/No. of Transfer, Transaction date, Amount of Transaction, Name of Bank, Address of Bank shall be furnished by the tenderer on their letterhead separately along with their tender.
8. **Refund of EMD:** The EMD will be returned to unsuccessful Tenderer only after the Tenders are finalized. In case of successful Tenderer, it will be retained till the successful and complete installation of the equipment.

9. **Reasonability of Prices:**

Please quote best minimum prices applicable for a premier Research institution, leaving no scope for any further negotiations on prices. The quoting party should give a certificate to the effect that the quoted prices are the minimum and they have not quoted the same item on lesser rates than those being offered to NIAMT to any other customer nor they will do so till the validity of offer or execution of the purchase order, whichever is later. We request you to fill the price reasonability certificate format in the enclosed file (Annexure "1")

The party must give details of identical or similar equipment, if any, supplied to any CSIR labs / DBT / DST institutes during last three years along with the final price paid and Performance certificate from them.

10. **Performance Security:** The supplier shall require submitting the performance security in the form of irrevocable bank guarantee issued by any Indian Nationalized Bank for an amount which is equal to the 10% of Purchase Order value within 15 days after the final Installation cum acceptance of the equipment at NIAMT and Performance Security should be valid for a period of 60 days beyond the date of completion of warranty period of the equipment.
11. **Force Majeure:** The Supplier shall not be liable for forfeiture of its performance security, liquidated damages or termination for default, if and to the extent that, it's delays in performance or other failure to perform its obligations under the Contract is the result of an event of Force Majeure.
- i. For purposes of this Clause, "Force Majeure" means an event beyond the control of the Supplier and not involving the Supplier's fault or negligence and not foreseeable. Such events may include, but are not limited to, acts of the Purchaser either in its sovereign or contractual capacity, wars or revolutions, fires, floods, epidemics, quarantine restrictions and freight embargoes.
  - ii. If a Force Majeure situation arises, the Supplier shall promptly notify the Purchaser in writing of such conditions and the cause thereof. Unless otherwise directed by the Purchaser in writing, the Supplier shall continue to perform its obligations under the Contract as far as is reasonably practical and shall seek all reasonable alternative means for performance not prevented by the Force Majeure event.
12. **Risk Purchase Clause:** In event of failure of supply of the item/equipment within the stipulated delivery schedule, the purchaser has all the right to purchase the item/equipment from the other source on the total risk of the supplier under risk purchase clause.
13. **Integrity Pact:**
- i. As per the directives of the Central Vigilance Commission all government departments / organizations / Institutes have to adopt an Integrity Pact (IP) to ensure transparency, equity and competitiveness in major public procurement activities. The integrity pact envisages an agreement between the prospective bidders/vendors with the buyer committing the persons/officials of both the parties with the aim not to exercise any corrupt influence on any aspect of the contract. Only those bidders/vendors who are willing to enter in to such an integrity pact with the purchaser would be competent to participate in the bidding.
  - ii. Integrity Pact also envisages Panel of Independent External Monitors (IEMs) which shall be provided / recommended by NIAMT / its labs and Institutes with the approval of by CVC.
  - iii. The integrity pact would be effective from the date of invitation of bids till complete execution of the contract.
  - iv. The model format of integrity pact (IP) is at Annexure - 6.

14. **Packing instructions:** Each package will be marked on three sides with proper paint/indelible ink, the following:
- i. Item Nomenclature
  - ii. Order / Contract No.
  - iii. Country of Origin of goods
  - iv. Supplier's Name and Address
  - v. Consignee details
  - vi. Packing list reference number

15. **Delivery and Documents:**

Delivery of the goods should be made within a maximum of 24 weeks from the date of placement of purchase order and the opening of LC. Within 24 hours of shipment, the supplier shall notify the purchaser and the insurance company by cable/telex/fax/e mail the full details of the shipment including contract number, railway receipt number/ AAP etc. and date, description of goods, quantity, name of the consignee, invoice etc. The supplier shall mail the following documents to the purchaser with a copy to the insurance company:

- i. 4 Copies of the Supplier invoice showing contract number, goods' description, quantity unit price, total amount.
- ii. Acknowledgment of receipt of goods from the consignee(s) by the transporter.
- iii. Insurance Certificate if applicable.
- iv. Manufacturer's/Supplier's warranty certificate.
- v. Inspection Certificate issued by the nominated inspection agency, if any, and the Supplier's factory inspection report; and
- vi. Certificate of Origin.
- vii. Two copies of the packing list identifying the contents of each package.
- viii. The above documents should be received by the Purchaser before arrival of the Goods (except where the Goods have been delivered directly to the Consignee with all documents) and, if not received, the Supplier will be responsible for any consequent expenses.

16. **Delayed delivery:** If the delivery is not made within the due date for any reason, the institute will have the right to impose penalty 0.5% per week and the maximum deduction is 10% of the contract value / price.

17. **Prices:** The price should be quoted in net per unit (after breakup) and must include all packing and delivery charges. The offer/bid should be exclusive of taxes and duties, which will be paid by the purchaser as applicable. However, the percentage of taxes & duties shall be clearly indicated. The price should be quoted without custom duty and excise duty, since NIAMT is exempted from payment of Excise Duty and is eligible for concessional rate of custom duty. Necessary certificate will be issued on demand.

In case of import supply the price should be quoted on FOB Basis. Also please indicate CIF charges separately up-to New Delhi indicating the mode of shipment. NIAMT will make necessary arrangements for the clearance of imported goods at the Airport/Seaport. Hence the price should not include the above charges.

18. **Notices:** For the purpose of all notices, the following shall be the address of the Purchaser and Supplier.

i) **Purchase :**                   **The Director,**  
National Institute of Advance Manufacturing Technology  
Hatia, Ranchi – 834 003 (Jharkhand).

ii) **Supplier:**                   (To be filled in by the supplier)

.....  
.....  
.....  
.....

19. **Progress of Supply:** Wherever applicable, supplier shall regularly intimate progress of supply, in writing, to the Purchaser as under:
- i. Quantity offered for inspection and date;
  - ii. Quantity accepted/rejected by inspecting agency and date;
  - iii. Quantity dispatched/delivered to consignees and date;
  - iv. Quantity where incidental services have been satisfactorily completed with date;
  - v. Quantity where rectification/repair/replacement effected/completed on receipt of any communication from consignee/Purchaser with date;
  - vi. Date of completion of entire Contract including incidental services, if any; and
  - vii. Date of receipt of entire payments under the Contract (In case of stage-wise inspection, details required may also be specified).
20. **Inspection and Tests:** Inspection and tests prior to shipment of Goods and at final acceptance are as follows:
- i. After the goods are manufactured and assembled, inspection and testing of the goods shall be carried out at the supplier's plant by the supplier, prior to shipment to check whether the goods are in conformity with the technical specifications attached to the purchase order. Manufacturer's test certificate with data sheet shall be issued to this effect and submitted along with the delivery documents. The purchaser shall be present at the supplier's premises during such inspection and testing if need is felt. The location where the inspection is required to be conducted should be clearly indicated. The supplier shall inform the purchaser about the site preparation, if any, needed for Installation of the goods at the purchaser's site at the time of submission of order acceptance.
  - ii. The acceptance test will be conducted by the Purchaser, their consultant or other such person nominated by the Purchaser at its option after the equipment is installed at purchaser's site in the presence of supplier's representatives. The acceptance will involve trouble free operation and ascertaining conformity with the ordered specifications and quality. There shall not be any additional charges for carrying out acceptance test. No malfunction, partial or complete failure of any part of the equipment is expected to occur. The Supplier shall maintain necessary log in respect of the result of the test to establish to the entire satisfaction of the Purchaser, the successful completion of the test specified.
  - iii. In the event of the ordered item failing to pass the acceptance test, a period not exceeding one weeks will be given to rectify the defects and clear the acceptance test, failing which the Purchaser reserve the right to get the equipment replaced by the Supplier at no extra cost to the Purchaser.
  - iv. Successful conduct and conclusion of the acceptance test for the installed goods and equipments shall also be the responsibility and at the cost of the Supplier.
21. **Resolution of Disputes:** The dispute resolution mechanism to be applied pursuant shall be as follows:
- i. In case of Dispute or difference arising between the Purchaser and a domestic supplier relating to any matter arising out of or connected with this agreement, such disputes or difference shall be settled in accordance with the Indian Arbitration & Conciliation Act, 1996, the rules there under and any statutory modifications or re-enactments thereof shall apply to the arbitration proceedings. The dispute shall be referred to the Director, National Institute of Advance Manufacturing Technology, NIAMT, Hatia, Ranchi – 834 003 (Jharkhand) and if he is unable or unwilling to act, to the sole arbitration of some other person appointed by him willing to act as such Arbitrator. The award of the arbitrator so appointed shall be final, conclusive and binding on all parties to this order.

- ii. In the case of a dispute between the purchaser and a Foreign Supplier, the dispute shall be settled by arbitration in accordance with provision of sub-clause (a) above. But if this is not acceptable to the supplier then the dispute shall be settled in accordance with provisions of UNCITRAL (United Nations Commission on International Trade Law) Arbitration Rules.
  - iii. The venue of the arbitration shall be the place from where the order is issued.
22. **Applicable Law:** The place of jurisdiction would be Ranchi (Jharkhand) INDIA.
23. **Right to Use Defective Goods:** If after delivery, acceptance, and Installation and within the guarantee and warranty period, the operation or use of the goods proves to be unsatisfactory, the Purchaser shall have the right to continue to operate or use such goods until rectifications of defects, errors or omissions by repair or by partial or complete replacement is made without interfering with the Purchaser's operation.
24. **Supplier Integrity:** The Supplier is responsible for and obliged to conduct all contracted activities in accordance with the Contract using state of the art methods and economic principles and exercising all means available to achieve the performance specified in the contract.
25. **Training:** The Supplier is required to train the designated Purchaser's technical and end user personnel to enable them to effectively operate the total equipment.
26. **Installation & Demonstration:** The supplier is required to done the Installation and demonstration of the equipment within one month of the arrival of materials at the NIAMT site of Installation, otherwise the penalty clause will be the same as per the supply of materials.
27. **Insurance:** For delivery of goods at the purchaser's premises, the insurance shall be obtained by the Supplier in an amount equal to 110% of the value of the goods from "warehouse to warehouse" (final destinations) on "All Risks" basis including War Risks and Strikes. The insurance shall be valid for a period of not less than 3 months after Installation and commissioning. ***In case of orders placed on FOB / FCA basis, the purchaser shall arrange Insurance.***
28. **Incidental services:** The incidental services also include:
  - i. Furnishing of 01 set of detailed operations & maintenance manual.
  - ii. Arranging the shifting/moving of the item to their location of final Installation within NIAMT premises at the cost of Supplier through their Indian representatives.
29. **Warranty:**
  1. Warranty period shall be at least 3 years from date of Installation of Goods at the NIAMT site of Installation. The Supplier shall, in addition, comply with the performance and/or consumption guarantees specified under the contract. If for reasons attributable to the Supplier, these guarantees are not attained in whole or in part, the Supplier shall at its discretion make such changes, modifications, and/or additions to the Goods or any part thereof as may be necessary in order to attain the contractual guarantees specified in the Contract at its own cost and expense and to carry out further performance tests. **The warranty should be comprehensive on site.**

**Note:** If the OEM warranty is for 12 Months, additional extended warranty of 24 months should be quoted separately with or without price. Also. If a different period of warranty has been specified in the 'Technical Specifications of the equipment' then the period mentioned above shall stand modified to that extent.

2. The Purchaser shall promptly notify the Supplier in writing of any claims arising under this warranty. Upon receipt of such notice, the Supplier shall immediately within in 02 days arrange to repair or replace the defective goods or parts thereof free of cost at the ultimate destination. The Supplier shall take over the replaced parts/goods at the time of their replacement. No claim whatsoever shall lie on the Purchaser for the replaced parts/goods thereafter. The period for correction of defects in the warranty period is 02 days. If the supplier having been notified fails to remedy the defects within 02 days, the purchaser may proceed to take such remedial action as may be necessary, at the supplier's risk and expenses and without prejudice to any other rights, which the purchaser may have against the supplier under the contract.
30. **AMC:** Annual Maintenance Contract (AMC) / Comprehensive Maintenance Contract (CMC) up to next five years after warranty period is over should be quoted separately.
31. **Delivery Schedule:** The tenderer should indicate clearly the time required for delivery of the item. In case there is any deviation in the delivery schedule, liquidated damages clause will be enforced or penalty for the delayed supply period will be levied.
32. **Governing Language:** The contract shall be written in English language. English language version of the Contract shall govern its interpretation. All correspondence and other documents pertaining to the Contract, which are exchanged by the parties, shall be written in the same language.
33. **Applicable Law:** The Contract shall be interpreted in accordance with the laws of the Union of India and all disputes shall be subject to place of jurisdiction.
34. **Notices:** Any notice given by one party to the other pursuant to this contract/order shall be sent to the other party in writing or by cable, telex, FAX or e mail and confirmed in writing to the other party's address.
- A notice shall be effective when delivered or on the notice's effective date, whichever is later.
35. **Taxes and Duties:** Suppliers shall be entirely responsible for all taxes, duties, license fees, octroi, road permits, etc., incurred until delivery of the contracted Goods to the Purchaser. However, VAT in respect of the transaction between the Purchaser and the Supplier shall be payable extra, if so stipulated in the order.
36. **Agency Commission:** Agency commission if any will be paid to the Indian agent in Rupees on receipt of the equipment and after satisfactory Installation. Agency Commission will not be paid in foreign currency under any circumstances. The details should be explicitly shown in Tender even in case of Nil commission. The tenderer should indicate the percentage of agency commission to be paid to the Indian agent.
37. **Payment:**
1. Payment will be made through irrevocable Letter of Credit (LC). Letter of Credit (LC) will be established in the favour of foreign Supplier after the submission of performance security. The letter of credit (LC) will be established on the exchange rates as applicable on the date of establishment.
    - i. For Imports, LC will be opened for 100% FOB/CIF value. 80% of the LC amount shall be released on presentation of complete and clear shipping documents and 20% of the LC amount shall be released after the Installation and demonstration of the equipment at the NIAMT site of Installation in faultless working condition for period of 60 days from the date of the satisfactory Installation and subject to the production of unconditional



performance bank guarantee as specified in Clause 9 of tender terms and conditions.

- ii. Indian Agency commission (IAC), if any shall be paid after satisfactory Installation & commissioning of the goods at the destination at the exchange rate prevailing on the date of negotiation of LC documents, subject to DGS&D registration for restricted items.
  - iii. All the bank charges within India will be borne by the institute and outside India will be borne by the Supplier.
2. For Indigenous supplies, 100% payment shall be made by the Purchaser after delivery, inspection, successful Installation, commissioning and acceptance of the equipment at NIAMT in good condition and to the entire satisfaction of the Purchaser and on production of unconditional performance bank guarantee as specified in Clause 11 of tender terms and conditions.

In case of indigenous supply, the 100% payment will be made through bank transfer after receipt & Installation of the equipment. The following bank details to be submitted along with tender:

- a). Name of Beneficiary:
- b). Account No.:
- c). Name of Bank:
- d). Bank Address:
- e). IFS Code:
- f). MICR Code:
- g). Swift Code:

38. **User list:** Brochure detailing technical specifications and performance, list of industrial and educational establishments where the items enquired have been supplied must be provided as per format attached in **annexure- 5**.

39. **Manuals and Drawings:**

- i Before the goods and equipments are taken over by the Purchaser, the Supplier shall supply operation and maintenance manuals. These shall be in such details as will enable the Purchaser to operate, maintain, adjust and repair all parts of the works as stated in the specifications.
- ii The Manuals shall be in the ruling language (English) in such form and numbers as stated in the contract.
- iii Unless and otherwise agreed, the goods equipment shall not be considered to be completed for the purposes of taking over until such manuals and drawing have been supplied to the Purchaser.

40. **Application Specialist:** The tenderer should mention in the Techno-Commercial bid the availability and names of Application Specialist and Service Engineers in the nearest regional office.

41. **Terms of Delivery:** The item should be supplied to our destination in case of local supply. In case of import supply, the item should be shipped up-to NIAMT, Ranchi. The Installation/Commissioning should be completed as specified.

42. **Site Preparation:** The supplier shall inform to the institute about the site preparation, if any, needed for the Installation of equipment, immediately after the receipt of the

purchase order. The supplier must provide complete details regarding space and all the other infrastructural requirements needed for the equipment, which the institute should arrange before the arrival of the equipment to ensure its timely Installation and smooth operation thereafter.

The supplier shall visit the institute and see the site where the equipment is to be installed and may offer his advice and render assistance to the institute in the preparation of the site and other pre-installation requirements.

43. **Installation:** The equipment or machinery has to be installed or commissioned by the successful bidder within 30 days from the date of receipt of the item at NIAMT. In case of any miss-happening / damage to equipment and supplies during the carriage of supplies from the origin of equipment to the Installation site, the supplier has to replace it with new equipment/supplies immediately at his own risk. Supplier will settle his claim with the insurance company as per his convenience. NIAMT will not be liable to any type of losses in any form.
44. **Spare Parts:** The Supplier may be required to provide any or all of the following materials, notifications, and information pertaining to spare parts manufactured or distributed by the Supplier:
- i. Such spare parts as the Purchaser may elect to purchase from the Supplier, providing that this election shall not relieve the Supplier of any warranty obligations under the Contract; and
  - ii. In the event of termination of production of the spare parts:
  - iii. Advance notification to the Purchaser of the pending termination, in sufficient time to permit the Purchaser to procure needed requirements; and
  - iv. Following such termination, furnishing at no cost to the Purchaser, the blueprints, drawings, and specifications of the spare parts, if requested.

Supplier shall carry sufficient inventories to assure ex-stock supply of consumable spares for the Goods, such as gaskets, plugs, washers, belts etc. Other spare parts and components shall be supplied as promptly as possible but in any case, within six months of placement of order.

45. **Defective Equipment:** If any of the equipment supplied by the Tenderer is found to be substandard, refurbished, un-merchantable or not in accordance with the description/specification or otherwise faulty, the committee will have the right to reject the equipment or its part. The prices of such equipment shall be refunded by the tenderer with 18% interest if such payments for such equipment have already been made. All damaged or unapproved goods shall be returned at suppliers cost and risk and the incidental expenses incurred thereon shall be recovered from the supplier. Defective part in equipment, if found before Installation and/or during warranty period, shall be replaced within 45 days on receipt of the intimation from this office at the cost and risk of supplier including all other charges.
46. **Termination for Default:** The Purchaser may, without prejudice to any other remedy for breach of contract, by written notice of default sent to the Supplier, terminate the Contract in whole or part:
- i. If the Supplier fails to deliver any or all of the Goods within the period(s) specified in the order, or within any extension thereof granted by the Purchaser; or
  - ii. If the Supplier fails to perform any other obligation(s) under the Contract.
  - iii. If the Supplier, in the judgment of the Purchaser has engaged in corrupt or fraudulent practices in competing for or in executing the Contract.

For the purpose of this Clause:

- i. "**Corrupt practice**" means the offering, giving, receiving, or soliciting of anything of value to influence the action of a public official in the procurement process or in contract execution. ii. "**Fraudulent practice**" means a misrepresentation of facts in order to influence a procurement process or the execution of a contract to the detriment of the Borrower, and includes collusive practice among Bidders (prior to or after bid submission) designed to establish bid prices at artificial non-competitive levels and to deprive the Borrower of the benefits of free and open competition;"
  - ii. In the event the Purchaser terminates the Contract in whole or in part, the Purchaser may procure, upon such terms and in such manner, as it deems appropriate, Goods or Services similar to those undelivered, and the Supplier shall be liable to the Purchaser for any excess costs for such similar Goods or Services. However, the Supplier shall continue the performance of the Contract to the extent not terminated.
47. **Training of Personnel:** The supplier shall be required to undertake to provide the technical training to the personnel involved in the use of the equipment at the institute premises, immediately after completing the Installation of the equipment for a minimum period of one week at the supplier's cost.
48. **Disputes and Jurisdiction:** Any legal disputes arising out of any breach of contract pertaining to this tender shall be settled in the court of competent jurisdiction located within Ranchi.
49. **Compliance certificate:** This certificate must be provided indicating conformity to the technical specifications.
50. **Acknowledgement:** It is hereby acknowledged that we have gone through all the conditions mentioned above and we agree to abide by them.

  
**Assistant Registrar-(S&P)**  
**NIAMT, Ranchi, Hatia**

**SIGNATURE OF TENDERER**  
**ALONG WITH SEAL OF THE COMPANY WITH DATE**



राष्ट्रीय उन्नत विनिर्माण प्रौद्योगिकी संस्थान  
(पूर्व नेशनल इंस्टीट्यूट ऑफ फाउंड्री एंड फोर्ज टेक्नोलॉजी)  
हटिया, राँची - 834 003 (झारखण्ड)

**National Institute of Advanced Manufacturing Technology**  
(Formerly National Institute of Foundry and Forge Technology)  
Hatia, Ranchi – 834 003 (Jharkhand)

**Annexure – 1**

**PRICE REASONABILITY CERTIFICATE (to be submitted in financial bid envelope)**

This is to certify that we have offered the maximum possible discount to you in our Quotation No. .... dated ..... for (Value Rs.) .....

We would like to certify that the quoted price are the minimum and we have not quoted the same item on lesser rates than those being offered to NIAMT to any other customer nor we will do so till the validity of offer or execution of purchase order, whichever is later.

**Seal and Signature of the Tenderer**



राष्ट्रीय उन्नत विनिर्माण प्रौद्योगिकी संस्थान  
(पूर्व नेशनल इंस्टीट्यूट ऑफ फाउंड्री एंड फोर्ज टेक्नोलॉजी)  
हटिया, राँची - 834 003 (झारखण्ड)

**National Institute of Advanced Manufacturing Technology**  
(Formerly National Institute of Foundry and Forge Technology)  
Hatia, Ranchi – 834 003 (Jharkhand)

**Annexure - 2**

Name of Equipment with Model No: .....

Name & Address of Manufacturer: .....

Price Quoted:

**A. or Indigenous Equipment:**

- i) Cost of equipment (Rs.): .....
- ii) GST (Rs.) : .....
- iii) Any other charges (Rs.) : .....
- iv) Total cost of equipment (in Rs.) F.O.R, NIFFT, Ranchi. : .....

**B. or Imported Equipment:**

- i) Cost of equipment (In Foreign Currency): .....
- ii) Packing and Forwarding: .....
- iii) CIF Price: .....
- iv) Freight charges up-to Ranchi Airport / Ranchi Railway Station: .....
- v) Insurance (110% of the cost of the equipment): .....
- vi) For NIFFT Ranchi: .....

Signature of Tenderer with date and seal



राष्ट्रीय उन्नत विनिर्माण प्रौद्योगिकी संस्थान  
(पूर्व नेशनल इंस्टीट्यूट ऑफ फाउंड्री एंड फोर्ज टेक्नोलॉजी)  
हटिया, राँची - 834 003 (झारखण्ड)

**National Institute of Advanced Manufacturing Technology**  
(Formerly National Institute of Foundry and Forge Technology)  
Hatia, Ranchi – 834 003 (Jharkhand)

Annexure-3

BID PARTICULARS

1. Name of the Supplier:
2. Address of the Supplier:
3. Availability of demonstration of equipment: Yes / No
4. Tender cost enclosed: Yes/No if yes
5. Online EMD submission information enclosed: Yes / No if Yes  
Transaction ID/No. of Transfer:.....  
Transaction date: .....  
Amount of Transaction: .....  
Name of Bank: .....  
Address of Bank: .....
6. Name and address of the Officer/contact person to whom all references shall be made regarding this tender enquiry  
Name:  
Address:  
Ph:  
Fax:  
Mobile:  
Email:  
Web:



## राष्ट्रीय उन्नत विनिर्माण प्रौद्योगिकी संस्थान

(पूर्व नेशनल इंस्टीट्यूट ऑफ फाउंड्री एंड फोर्ज टेक्नोलॉजी)

हटिया, राँची - 834 003 (झारखण्ड)

**National Institute of Advanced Manufacturing Technology**

(Formerly National Institute of Foundry and Forge Technology)

Hatia, Ranchi – 834 003 (Jharkhand)

Annexure-4A

### Compliance Statement (Technical bid)

Sl. No.	Check list of documents / Undertakings	Yes / No	Page No.	Remarks (give explanation if the answer is No)
01.	Is EMD details attached? (if applicable)			
02.	Is the bidder original equipment manufacturer (OEM)/authorized dealer?			
03.	If authorized dealer, recent dated certificate to this effect from OEM, attached or not?			
04.	Undertaking from OEM regarding technical support & extended warranty period.			
05.	Validity of 180 days or not?			
06.	Price Reasonability Certificate enclosed as per format?			
07.	Undertaking from bidder regarding acceptance of tender Terms & Conditions			
08.	Whether list of reputed users (along with telephone numbers of contact persons) for the past three years specific to the instrument attached as per annexure- 5			
09.	Does the instrument comply with all the specifications detailed? Attach a separate sheet showing compliance with the specifications and explanations thereto if the equipment varies from the requested specifications.			
10.	Whether free installation, Commissioning and Application Training offered?			
11.	Whether comprehensive onsite warranty offered?			
12.	Whether Annual maintenance after expiry of comprehensive onsite warranty quoted separately?			
13.	Whether free of cost shifting of instrument from transit campus to main campus offered?			



राष्ट्रीय उन्नत विनिर्माण प्रौद्योगिकी संस्थान

(पूर्व नेशनल इंस्टीट्यूट ऑफ फाउंड्री एंड फोर्ज टेक्नोलॉजी)

हटिया, राँची - 834 003 (झारखण्ड)

**National Institute of Advanced Manufacturing Technology**

(Formerly National Institute of Foundry and Forge Technology)

**Hatia, Ranchi – 834 003 (Jharkhand)**

**Annexure – 4B**

**Compliance Statement of Technical Specification**

Sl. No.	Parameter as per Annexure-7	Yes / No	Page No.	Remarks

**Place:-**

**Authorized Signatory  
Seal of bidders**

**Date:-**





राष्ट्रीय उन्नत विनिर्माण प्रौद्योगिकी संस्थान  
(पूर्व नेशनल इंस्टीट्यूट ऑफ फाउंड्री एंड फोर्ज टेक्नोलॉजी)  
हटिया, राँची - 834 003 (झारखण्ड)

**National Institute of Advanced Manufacturing Technology**  
(Formerly National Institute of Foundry and Forge Technology)  
Hatia, Ranchi – 834 003 (Jharkhand)

**Annexure - 5**

**List of Clients (for the equipment supplied within 5 years)**

S.No	Name of organization with address	Model no. of equipment supplied	Date of supply	Purchase order reference number	Contract person with contract details- email/mobile no
1					
2					
3					
4					
5					
6					
7					
8					
9					
10					
11					
12					

**Note: - Please attach a copy of purchase order for the supply as referred above.**

**Authorized Signatory  
Seal of bidders**



राष्ट्रीय उन्नत विनिर्माण प्रौद्योगिकी संस्थान  
(पूर्व नेशनल इंस्टीट्यूट ऑफ फाउंड्री एंड फोर्ज टेक्नोलॉजी)  
हटिया, राँची - 834 003 (झारखण्ड)

**National Institute of Advanced Manufacturing Technology**  
(Formerly National Institute of Foundry and Forge Technology)  
Hatia, Ranchi – 834 003 (Jharkhand)

Annexure - 6

**Format of the Integrity Pact**

**INTEGRITY PACT**

This **INTEGRITY PACT** is made and executed at..... on this day of.....,20.....

BY AND BETWEEN

**THE PRESIDENT OF INDIA** acting through **National Institute of Advance Manufacturing Technology, Hatia Ranchi**, Department of Higher Education Department of School Education, Ministry of Education, Govt of India having its office located at Shastri Bhawan, New Delhi-110001(hereinafter referred to as "The Principal" which terms of expression shall, unless excluded by or repugnant to the subject or context mean and include its successor-in office, administrators or permitted assignces) of the First Part;

**AND**

M/s ..... a company incorporated under the Companies Act,..... through its representative/authorized signatory ..... vide resolution dated .....passed by the Board of Directors, having its office at.....(hereinafter referred to as "**The Bidder/Contractor**" which term or expression shall, unless excluded by or repugnant to the subject or context, mean and include its successor-in-office, administrators or permitted assignces) of the **Second Part**.

**Preamble**

The Principal intends to award, under laid down organizational procedures, contracts for ..... The Principal values full compliance with all relevant laws of the land, rules, regulations, economic use of resources and of fairness/transparency in its relations with its Bidder(s) and/or Contractor(s).

In order to achieve these goals, the Principal will appoint Independent External Monitors (TEMs) who will monitor the tender process and the execution of the contract for compliance with the principles mentioned above.

## **Section 1- Commitments of the Principal**

- 1) The Principal commits itself to take all measures necessary to prevent corruption and to observe the following principles: -
  - a) No employee of the Principal, personally or through family members, will in connection with the tender for, or the execution of a contract, demand, take a promise for or accept, for self or third person, any material or immaterial benefit which the person is not legally entitled to.
  - b) The Principal will, during the tender process treat all Bidder(s) with equity and reason. The Principal will in particular, before and during the tender process, provide to all Bidder(s) the same information and will not provide to any Bidder(s) confidential / additional information through which the Bidder(s) could obtain an advantage in relation to the tender process or the contract execution.
  - c) The Principal will exclude from the process all known prejudiced persons.

If the Principal obtains information on the conduct of any of its employees which is a criminal offence under the IPC/PC Act, or if there be a substantive suspicion in this regard, the Principal will inform the Chief Vigilance Officer and in addition can initiate disciplinary actions.

## **Section 2- Commitments of the Bidder(s) Contractor(s)**

- 1) The Bidder(s)/ Contractor(s) commit themselves to take all measures necessary to prevent corruption. The Bidders(s) Contractor(s) comma themselves to observe the following principles during participation in the tender process and during the contract execution
  - a) The Bidder(s)/ Contractor (s) will not, directly or through any other person or firm, offer, promise or give to any of the Principal's employees involved in the tender process of the execution of the contract or to any third person any material or other benefit which he/she is not legally entitled to, in order to obtain in exchange any advantage of any kind whatsoever. during the tender process or during the execution of the contract
  - b) The Bidders(s)/ Contractor(s) will not enter with other Bidders into any undisclosed agreement or understanding, whether formal or informal. This applies in particular to prices, specifications, certifications, subsidiary contracts, submission or non-submission of bids or any other actions to restrict competitiveness or to introduce cartelization in the bidding process
  - c) The Bidder(s)/ Contractor(s) will not commit any offence under the relevant IPC/PC Act, further the Bidders(s)/ Contractor(s) will not use improperly, for purposes of competition or personal gain, or pass on to others, any information or document provided by the Principal as part of the business relationship, regarding plans, technical proposals and business details, including information contained or transmitted electronically.
  - d) The Bidder(s)/ Contractors(s) of foreign origin shall disclose the name and address of the Agents/representatives in India, if any. Similarly the Bidder(s)/Contractors(s) of Indian

Nationality shall furnish the name and address of the foreign principals, if any. Further details as mentioned in the "Guidelines on Indian Agents of Foreign Suppliers" shall be disclosed by the Bidder(s)/Contractor(s). Further, as mentioned in the Guidelines all the payments made to the Indian agent/representative have to be in Indian Rupees only. Copy of the "Guidelines on Indian Agents of Foreign Suppliers" is placed at (page no. 6)

- e) The Bidder(s)/ Contractor(s) will, when presenting their bid, disclose any and all payments made, is committed to or intends to make to agents, brokers or any other intermediaries in connection with the award of the contract.
  - f) Bidder(s)/ Contractor(s) who have signed the Integrity Pact shall not approach the Courts while representing the matter to IEMs and shall wait for their decision in the matter.
- 2) The Bidder(s) /Contractor(s) will not instigate third persons to commit offences outlined above or be an accessory to such offences.

### **Section 3-Disqualification from tender process and exclusion from future contracts**

If the Bidder(s)/Contractor(s), before award or during execution has committed a transgression through a violation of Section 2, above or in any other form such as to put their reliability or credibility in question, the Principal is entitled to disqualify the Bidder(s)/Contractor(s) from the tender process or take action as per the procedure mentioned in the "Guidelines on Banning of business dealings" Copy of the "Guidelines on Banning of business dealings".

### **Section 4-Compensation for Damages**

- (1) If the Principal has disqualified the Bidder(s) from the tender process prior to the award according to Section 3, the Principal entitled to demand and recover the damages equivalent to Earnest Money Deposit/Bid Security
- (2) If the Principal has terminated the contract according to Section 3, or if the Principal is entitled to terminate the contract according to Section 3, the Principal shall be entitled to demand and recover from the Contractor liquidated damages of the Contract value or the amount equivalent to Performance Bank Guarantee.

### **Section 5-Previous transgression**

- (1) The Bidder declares that no previous transgressions occurred in the last three years with any other Company in any country conforming to the anti-corruption approach or with any Public Sector Enterprise in India that could justify his exclusion from the tender process

- (2) If the Bidder makes incorrect statement on this subject, he can be disqualified from the tender process or action can be taken as per the procedure mentioned in "Guidelines on Banning of business dealings"

#### **Section 6-Equal treatment of all Bidders/Contractors/Subcontractors**

- 1) In case of Sub-contracting, the Principal Contractor shall take the responsibility of the adoption of Integrity Pact by the Sub-contractor.
- 2) The Principal will enter into agreements with identical conditions as this one with all Bidder and Contractors.
- 3) The Principal will disqualify from the tender process all bidders who do not sign this Pact or violate this provision.

#### **Section 7-Criminal charges against violating Bidder(s)/Contractor(s)/Subcontractor(s)**

If the Principal obtains knowledge of conduct of a Bidder, Contractor or Subcontractor, or of an employee or a representative or an associate of a Bidder, Contractor or Subcontractor which constitutes corruption, or if the Principal has substantive suspicion in this regard, the Principal will inform the same to the Chief Vigilance Officer.

#### **Section 8-Independent External Monitor**

- 1) The Principal appoints competent and credible Independent External Monitor for this Pact after approval by Central Vigilance Commission. The task of the Monitor is to review independently and objectively, whether and to what extent the parties comply with the obligations under this agreement.
- 2) The Monitor is not subject to instructions by the representatives of the parties and performs his/her functions neutrally and independently. The Monitor would have access to all Contract documents, whenever required. It will be obligatory for him/her to treat the information and documents of the Bidders/Contractors as confidential. He/she reports to Secretary, MoE.
- 3) The Bidder(s)/Contractor(s) accepts that the Monitor has the right to access without restriction to all Project documentation of the Principal including that provided by the Contractor. The Contractor will also grant the Monitor, upon her request and demonstration of a valid interest, unrestricted and unconditional access to their project documentation. The same is applicable to Sub-contractors.
- 4) The Monitor is under contractual obligation to treat the information and documents of the Bidder(s)/Contractor(s) (and Sub-contractors) with confidentiality. The Monitor has also signed declarations on 'Non-Disclosure of Confidential Information and of "Absence of Conflict of Interest. In case of any conflict of interest arising at a later date the IEM shall inform Secretary, D/o Higher Education.
- 5) The Principal will provide to the Monitor sufficient information about all meeting among the parties related to the Project provided such meetings could have an impact on the contractual relations between the Principal and the Contractor. The parties offer to the Monitor the option to participate in such meetings.

- 6) As soon as the Monitor notices, or believes to notice, a violation of this agreement, he/she will so inform the Management of the Principal and request the Management to discontinue or take corrective action, or to take other relevant action. The monitor can in this regard submit non-binding recommendations. Beyond this, the Monitor has no right to demand from the parties that they act in a specific manner, refrain from action or tolerate action.
- 7) The Monitor will submit a written report to the Secretary, D/o Higher Education within 8 to 10 weeks from the date of reference or intimation to him by the Principal and, should the occasion arise, submit proposals for correcting problematic situations.
- 8) If the Monitor has reported to the Secretary, D/o Higher Education, a substantiated suspicion of an offence under relevant IPC/ PC Act, and the Secretary, MoE has not, within the reasonable time taken visible action to proceed against such offence or reported it to the Chief Vigilance Officer, the Monitor may also transmit this information directly to the Central Vigilance Commissioner.
- 9) The word 'Monitor' would include both singular and plural.

### **Section 9-Pact Duration**

This Pact begins when both parties have legally signed it. It expires for the Contractor 12 months after the last payment under the contract, and for all other Bidders 6 months after the contract has been awarded. Any violation of the same would entail disqualification of the bidders and exclusion from future business dealing.

If any claim is made / lodged during this time, the same shall be binding and continue to be valid despite the lapse of this pact as specified above, unless it is discharged / determined by Secretary, D/o Higher Education.

### **Section 10-Other provisions**

- 1) This agreement is subject to Indian Law Place of performance and jurisdiction is the Office of the Principal, i.e. New Delhi.
- 2) Changes and supplements as well as termination notices need to be made in writing. Side agreements have not been made.
- 3) If the Contractor is a partnership or a consortium, this agreement must be signed by all partners or consortium members.
- 4) Should one or several provisions of this Pact to out to be invalid, the remainder of this Pact remains valid In this case, the parties will strive to come to an agreement to their original intentions.
- 5) Issues like Warranty / Guarantee etc. Shall be outside the purview of IEM.
- 6) In the event of any contradiction between the Integrity Pact and its Annexure, the Clause in the Integrity pact will prevail.

7) The actions stipulated in this Integrity Pact are without prejudice to any other legal action(s) that may follow in accordance with the provisions of the extant law in force relating to any civil or criminal proceedings.

**IN WITNESS WHEREOF**, the parties hereunto set their hands and seals and executed this INTEGRITY PACT as of the day/month/year first above written:

For and on behalf of  
**THE PRESIDENT OF INDIA (First Party)**  
SIGNED, SEALED AND DELIVERED by

**Name:** .....  
**Designation:** .....  
**Address:** .....  
**Authorized Signatory**

For and on behalf of  
**M/s.....(Second Party)**  
SIGNED, SEALED AND DELIVERED by

**Name:** .....  
**Designation:** .....  
**Address:** .....  
**Representative/authorized signatory**  
**Vide resolution dated..... passed by the Board of Directors**

**In the presence of Witness: -**

- 1.
- 2.



## राष्ट्रीय उन्नत विनिर्माण प्रौद्योगिकी संस्थान

(पूर्व नेशनल इंस्टीट्यूट ऑफ फाउंड्री एंड फोर्ज टेक्नोलॉजी)

हटिया, राँची - 834 003 (झारखण्ड)

**National Institute of Advanced Manufacturing Technology**

(Formerly National Institute of Foundry and Forge Technology)

Hatia, Ranchi – 834 003 (Jharkhand)

Annexure - 7

### Technical Specification of Fabricated Powder Extruder.

#### Hydraulic Press: -

1. Platen Size: 500 x 500 mm.
2. Day Light Gap: 300 mm.
3. Powder Filling: Manually in the cylindrical barrel.
4. Hydraulic motor: 7.5 HP, 1500 rpm.
5. Maximum Work Pressure: 210 kg/cm<sup>2</sup>.
6. Direction: Horizontal type press.
7. Overall Dimension: Approx: 1800 (L) x 900 (W) x 800 (H).
8. Weight of the machine: Approx: 2200 kg.
9. Stroke: 300 mm.
10. RAM diameter: 80 mm.
11. PLC Controller: To do stepwise programming of pressure (Min 7 steps required).

#### Steps: -

- i. User input the values of pressure and temp after switching on the machine. The extremes that the machine will be capable of: Load: 50 tonnages; pressure holding time: 10 min; sintering temperature: 1000°C; sintering time: 1 hr.; ram speed: 1-100 mm/sec (0.5 mm/sec).
- ii. Piston move to compress the powder.
- iii. Hydraulic stops i.e., pressure value becomes zero.
- iv. If hydraulic jam, machine get switch off.
- v. If everything fine then the hydraulic machine starts again and presses the compact into the sintering zone.
- vi. Hydraulic machine switch off and pressure value becomes zero.
- vii. Heating coil get switch on and temp build up.
- viii. After sintering the heating element get switch off.
- ix. If temperature overshoot then machine get switch off.
- x. If everything is fine then the hydraulic machine switch on and pushed the sintered part in the die and extrude it.
- xi. Machine switch off and comes to neutral.



### **Heating Element: -**

1. Resistance heating using Kanthal wire.
2. Thermocouple: K-type.
3. PLC Controller: To do stepwise programming of pressure (Min 7 steps required).
4. Present only over the Sintering Zone.

### **Die Assembly: -**

1. As per the drawing, given as an attachment (Annexure-8).

### **Turn Table: -**

1. Manually operated.
2. Diameter: 250 mm.
3. 360 degree endless rotation function.
4. Manual spin air bearing.

The turn table will be use to facilitate the user to easy movement of compaction die and die support. Initially both compaction die and die support lie on the table. During compaction, user manually, move compaction die along the guiding rod to fix it in front of the cylinder barrel where the powder is filled. After compaction the user move back the die on the table. Then user the table 180 degree to bring the die support in the front and move towards the cylinder barrel to extrude the compact part.

### **Cooling Unit: -**

1. Motor for water supply: 1.5 HP
2. Water tank 250 liter.



राष्ट्रीय उन्नत विनिर्माण प्रौद्योगिकी संस्थान  
(पूर्व नेशनल इंस्टीट्यूट ऑफ फाउंड्री एंड फोर्ज टेक्नोलॉजी)  
हटिया, राँची - 834 003 (झारखण्ड)

**National Institute of Advanced Manufacturing Technology**  
(Formerly National Institute of Foundry and Forge Technology)  
Hatia, Ranchi – 834 003 (Jharkhand)

Annexure - 8

Drawing of Fabricated Powder Extruder

**Design Details of Fabricated Powder Extruder Machine**

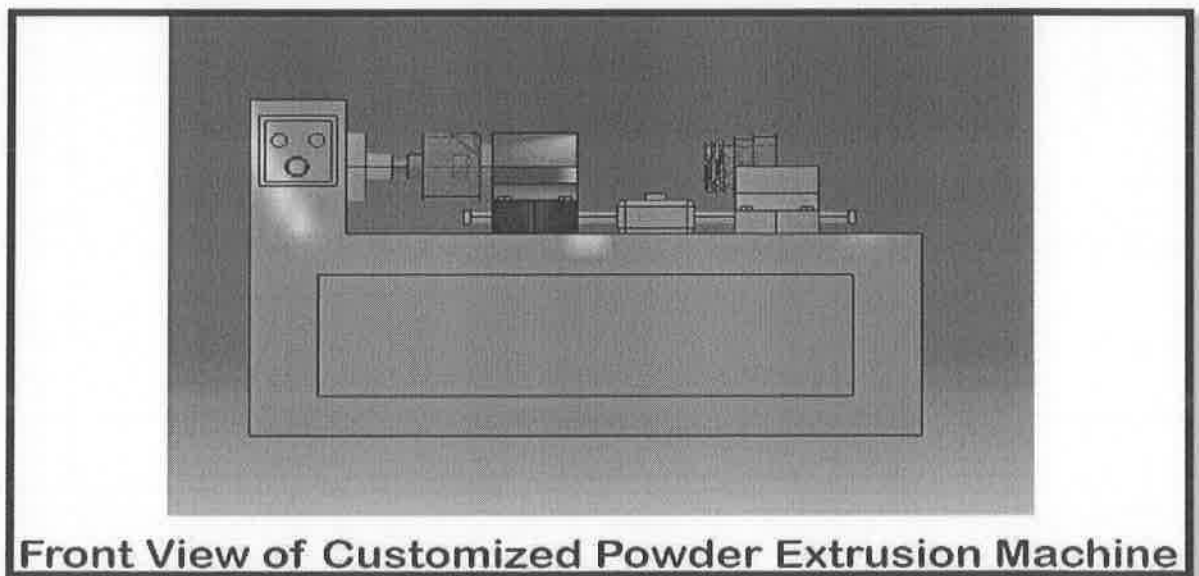
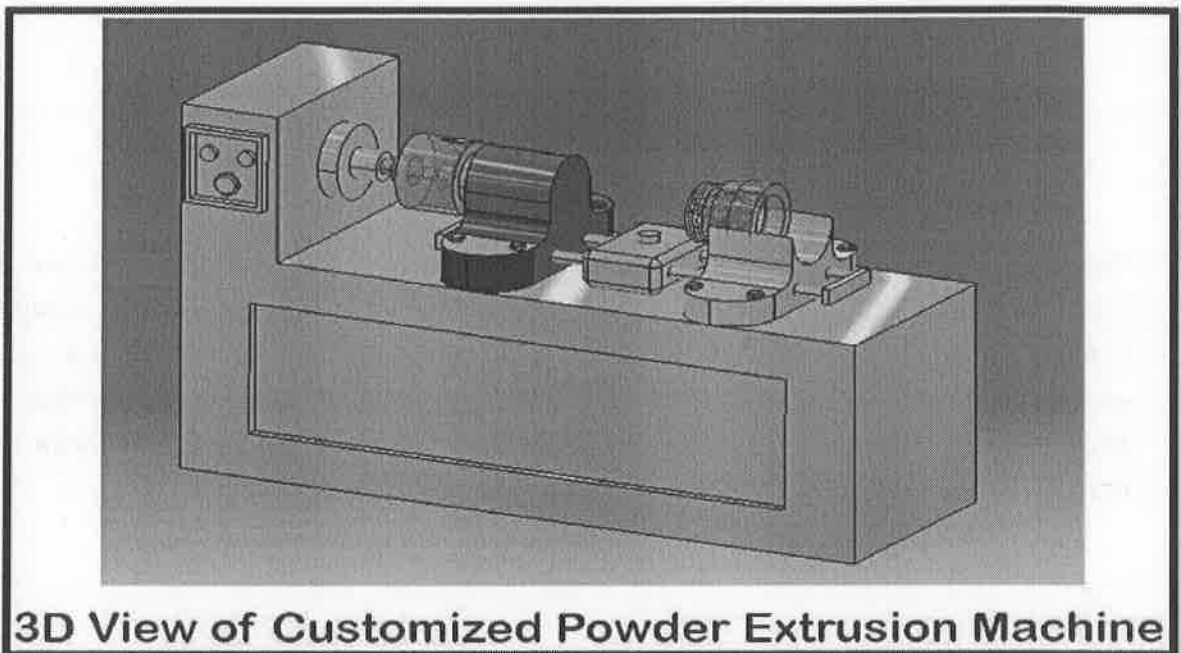

Note: The drawings given above are without die support and heat exchanger.

# Design Details of Fabricated Powder Extruder Machine

## PLUNGER

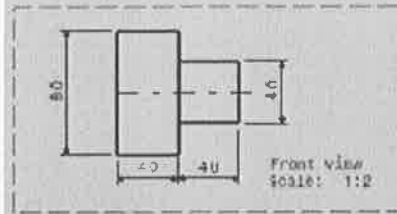
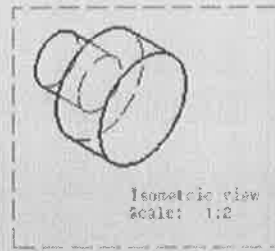
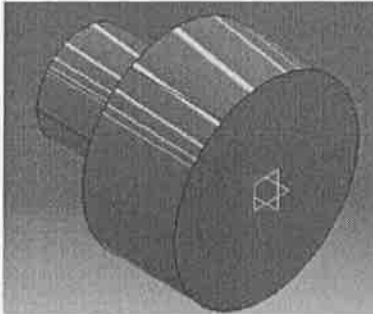

## CYLINDRICAL BARREL

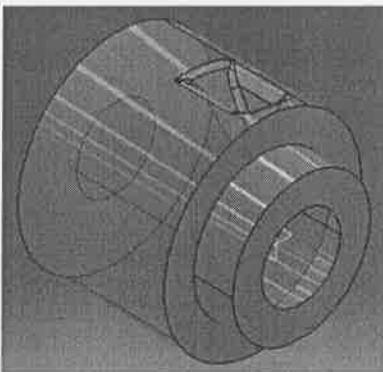

All Dimensions in : mm

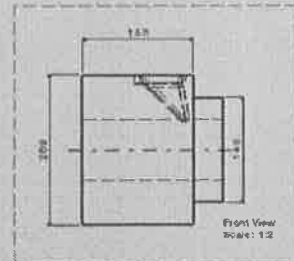
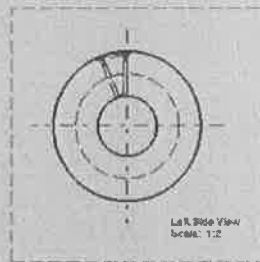
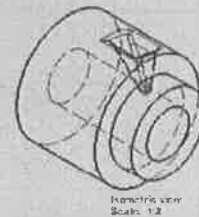

## FOLLOWER PAD

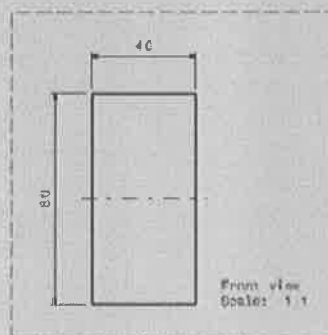
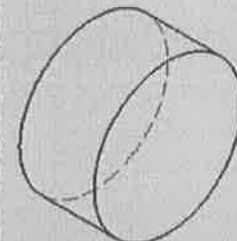
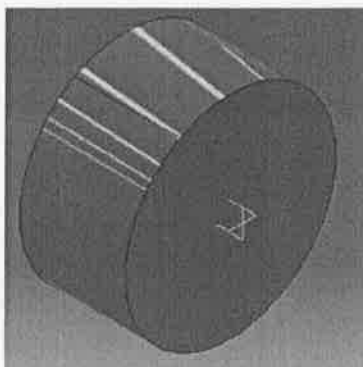

# Design Details of Fabricated Powder Extruder Machine

## BACK SUPPORT

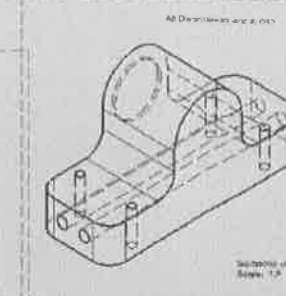
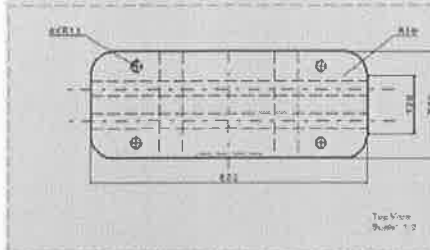
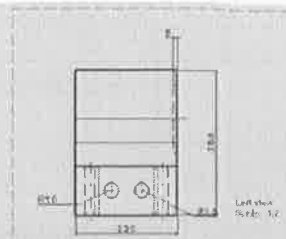
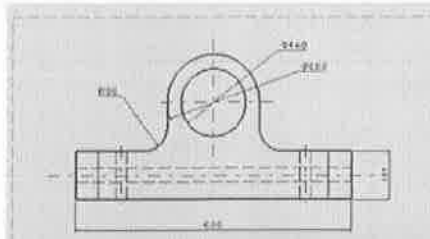
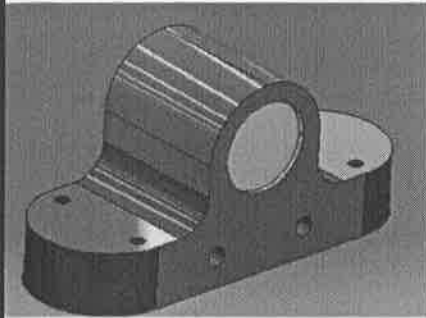

## SINTERING ZONE

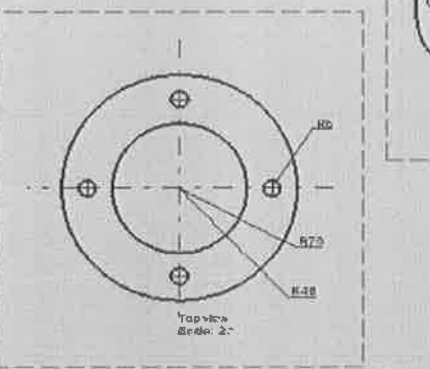
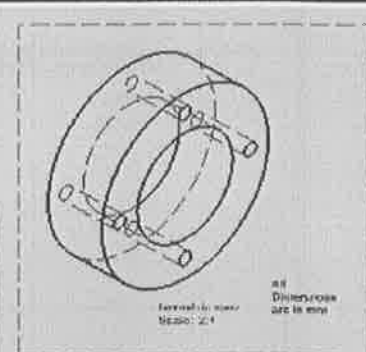
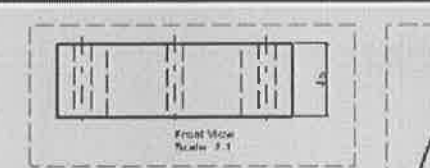
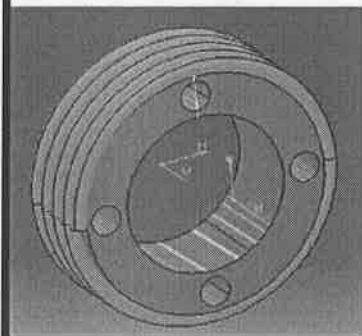

## DIE RING

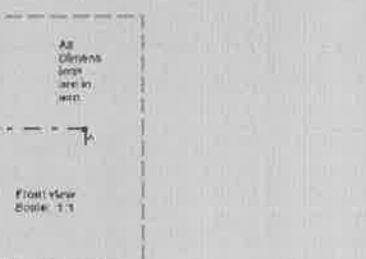
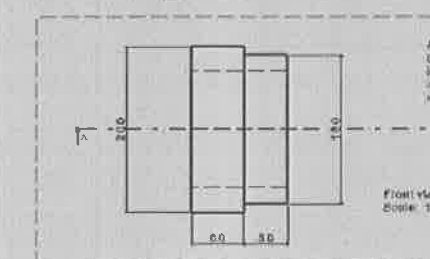
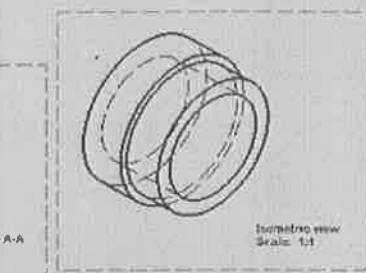
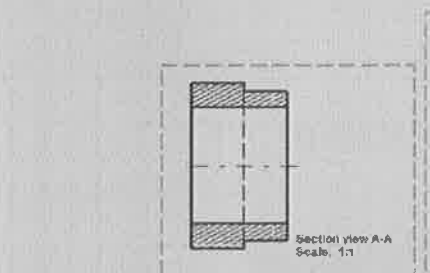
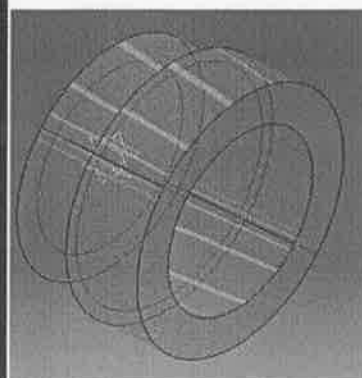

# Design Details of Fabricated Powder Extruder Machine

## REDUCTION ZONE

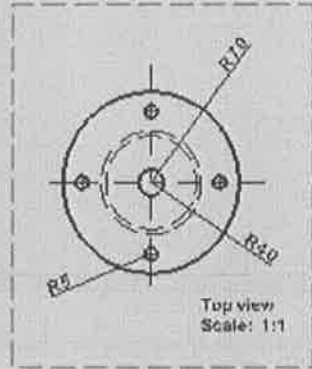
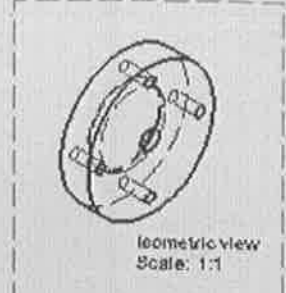
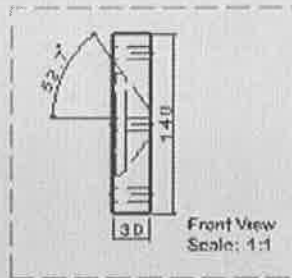
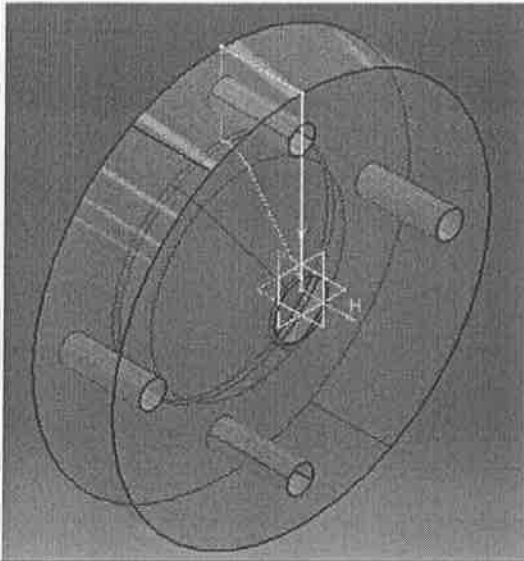

All Dimensions are in mm

## BEARING ZONE

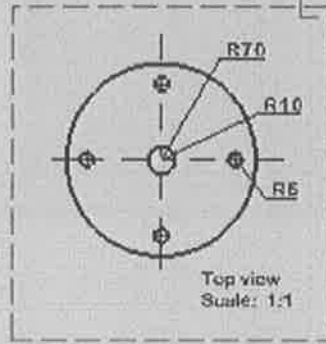
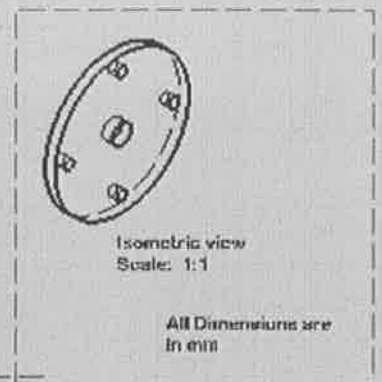
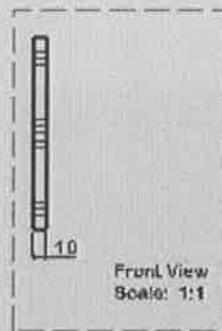
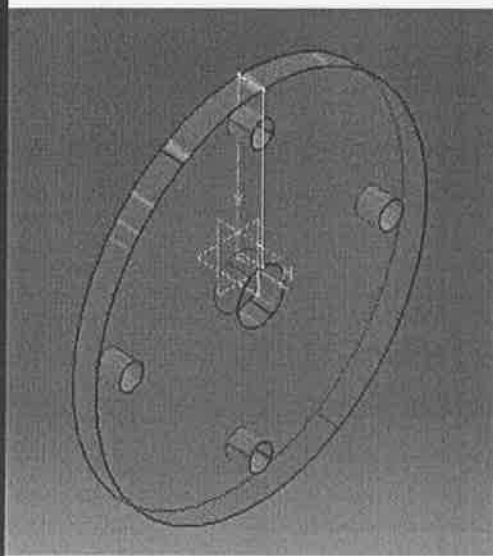

All Dimensions are in mm

# Design Details of Fabricated Powder Extruder Machine

## EXIT ZONE

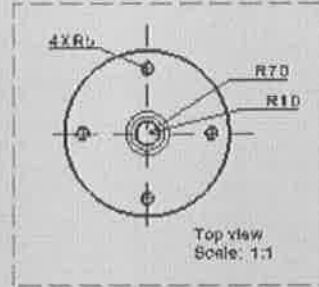
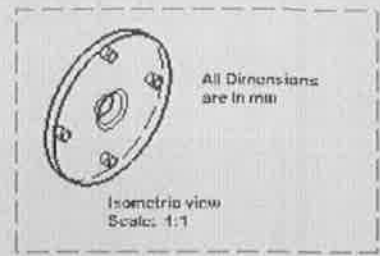
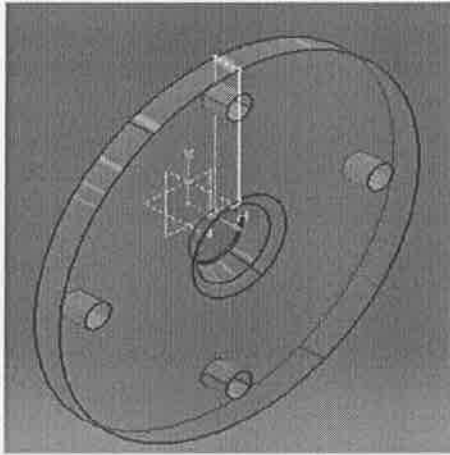

## BOLDSTER PLATE

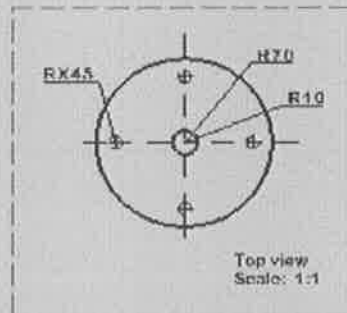
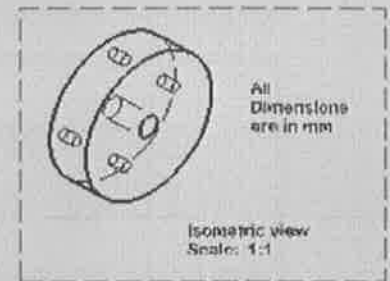
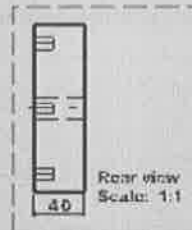
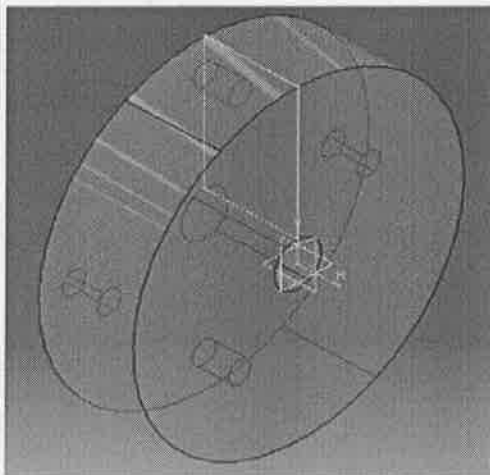

# Design Details of Fabricated Powder Extruder Machine

## HEAT EXCHANGER

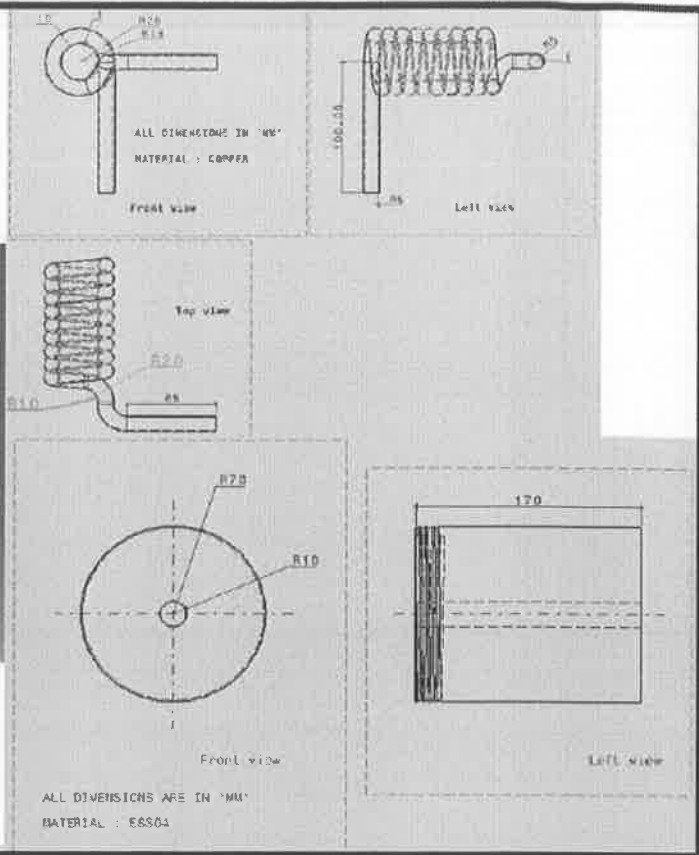
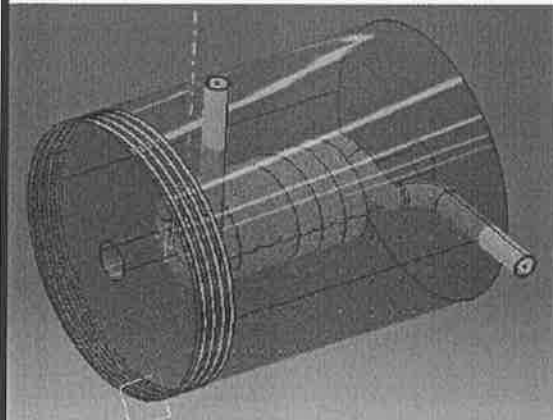

## DIE SUPPORT

